

MODEL H

Horizontally split cover

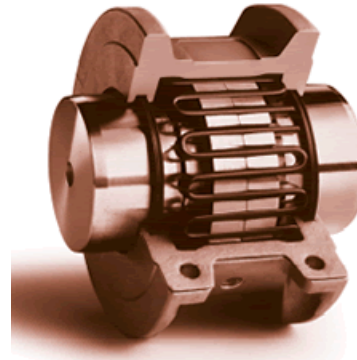
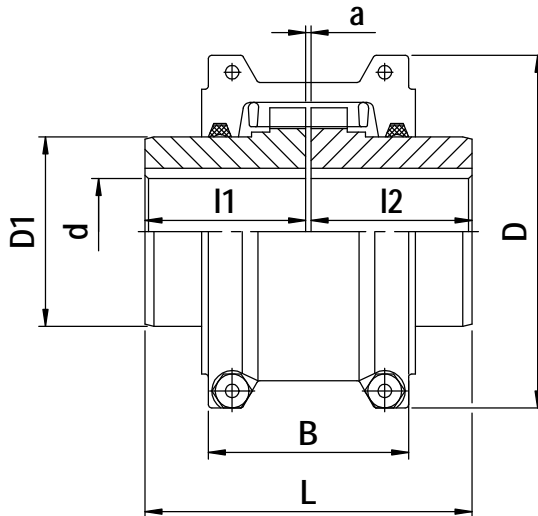

Size	Nominal torque TN	(1) Speed Max. r.p.m.	DIMENSIONS (mm)								J (3) Kgm ²	(4) Weight Kg.
			d (2) max.	d min.	D	D1	l1=l2	a	B	L		
2H	48	4500	27	13	102	40	48	3	67	98	0.0014	1.8
3H	136	4500	35	13	111	49	48	3	68	98	0.0022	2.4
4H	230	4500	44	13	118	57	51	3	70	105	0.0033	3.2
5H	400	4500	51	13	138	67	60	3	79	124	0.0073	5.2
6H	620	4350	57	19	151	76	64	3	92	130	0.0119	7
7H	900	4125	68	19	162	87	76	3	95	156	0.0185	10
8H	1860	3600	83	25	194	105	89	3	116	181	0.0451	18
9H	3390	3600	95	25	213	124	98	3	122	200	0.0787	25
10H	5700	2440	108	42	251	142	121	5	156	246	0.1782	41
11H	8470	2250	117	42	270	160	127	5	163	259	0.2701	54
12H	12430	2025	137	60	308	179	149	6.5	192	305	0.5136	79
13H	18080	1800	165	66	347	218	162	6.5	195	330	0.9885	118
14H	25990	1650	184	66	384	254	183	6.5	202	375	1.8454	176

(1) Subject to confirmation.

(2) Max. bore for keyways to DIN 6885/1

(3) $GD^2 = 4J$. // (3) and (4) values with no bore.

Equivalences

<u>Size</u>	<u>Falk equivalent</u>	<u>Size</u>	<u>Falk equivalent</u>	<u>Size</u>	<u>Falk equivalent</u>
2H	20T10 1020T10	7H	70T10 1070T10	12H	120T10 1120T10
3H	30T10 1030T10	8H	80T10 1080T10	13H	130T10 1130T10
4H	40T10 1040T10	9H	90T10 1090T10	14H	140T10 1140T10
5H	50T10 1050T10	10H	100T10 1100T10		
6H	60T10 1060T10	11H	110T10 1110T10		

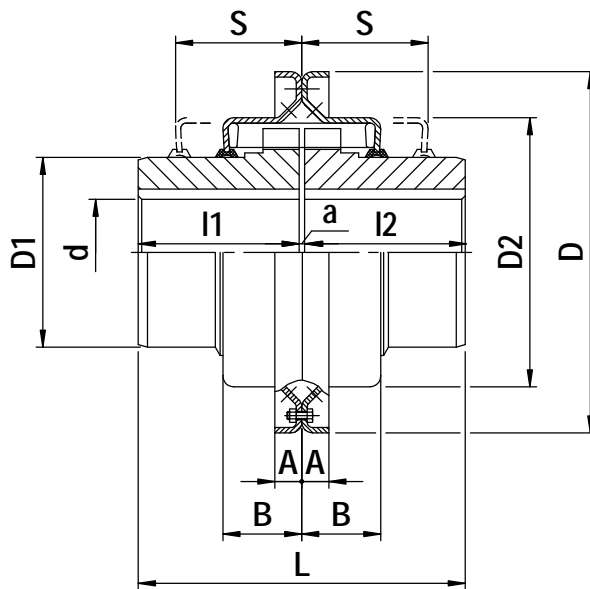

MODEL V & VT

Vertically split cover

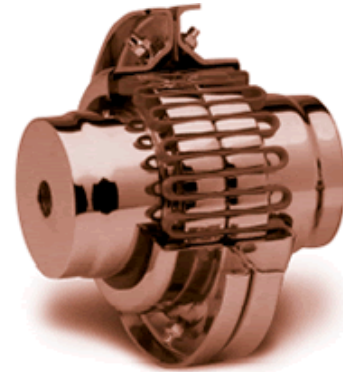

Size	Nominal torque TN	(1) Speed Max. r.p.m.	DIMENSIONS (mm)											J (4) Kg ^{m2}	(5) Weight Kg.
			d (2) max.	d min.	D	D2	D1	l1=l2	a	A	B	L	S(3)		
2V	48	6000	27	13	111	63	40	48	3	9.5	24	98	48	0.0011	1.6
3V	136	6000	35	13	121	72	49	48	3	9.5	25	98	48	0.0018	2.2
4V	230	6000	44	13	129	80	57	51	3	9.5	26	105	51	0.0027	3
5V	400	6000	51	13	148	97	67	60	3	13	31	124	61	0.0063	5
6V	620	6000	57	19	162	110	76	64	3	13	32	130	64	0.0100	7
7V	900	5500	68	19	173	121	87	76	3	13	34	156	67	0.0160	10
8V	1860	4750	83	25	200	149	105	89	3	13	44	181	89	0.0390	17
9V	3390	4000	95	25	232	168	124	98	3	13	47	200	96	0.0720	24
10V	5700	3250	108	42	267	198	142	121	5	16	60	246	121	0.1720	40
11V	8470	3000	117	42	286	216	160	127	5	16	63	259	124	0.2610	52
12V	12430	2700	137	60	319	246	179	149	6.5	16	74	305	143	0.5000	76
13V	18080	2400	165	66	378	284	218	162	6.5	22	75	330	147	1.0800	115
14V	25990	2200	184	66	416	322	254	183	6.5	22	78	375	156	1.8950	173
28VT	48000	2000	230	75	494	427	330	155	4	22	62.5	314	126	4.65	245
43VT	70000	1500	230	85	595	522	330	180	4	25	62.5	364	126	8.25	327
70VT	120000	1500	230	95	595	528	330	200	4	25	100	404	201	11.5	409
95VT	160000	1250	270	105	670	598	380	230	4	25	103	464	201	20.25	579

- (1) For higher speed, please consult.
 (2) Max. bore for keyways to DIN 6885/1
 (3) S = Space necessary to mount grids.
 (4) $GD^2 = 4J$. // (4) and (5) values with no bore.

Equivalences

<u>Size</u>	<u>Falk equivalent</u>	<u>Size</u>	<u>Falk equivalent</u>	<u>Size</u>	<u>Falk equivalent</u>
2V	20T20 1020T20	7V	70T20 1070T20	12V	120T20 1120T20
3V	30T20 1030T20	8V	80T20 1080T20	13V	130T20 1130T20
4V	40T20 1040T20	9V	90T20 1090T20	14V	140T20 1140T20
5V	50T20 1050T20	10V	100T20 1100T20		
6V	60T20 1060T20	11V	110T20 1110T20		

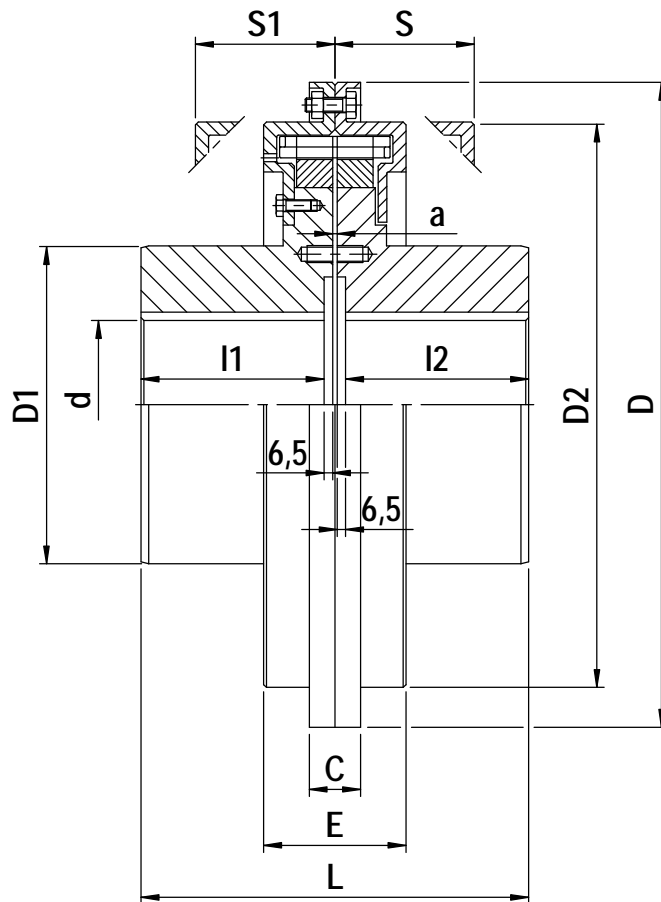

MODEL VS

Vertically split cover



Size	Nominal torque TN Nm	(1) Speed Max. r.p.m	DIMENSIONS (mm)												(3) J Kgm ²	(4) Weight Kg
			d (2) max.	d min.	D	D2	D1	I1=I2	a	C	E	L	(2) S	(2) S1		
150VS	270000	950	270	120	890	773	410	270	4	76	224	557	210	215	64,5	990
220VS	400000	800	300	165	1015	910	450	300	5	80	220	618	210	215	110,8	1260
300VS	540000	700	340	180	1180	1050	550	340	5	92	224	698	210	215	206,3	1860
380VS	700000	600	370	180	1320	1195	600	370	5	92	224	758	210	215	340	2390
480VS	800000	600	390	180	1360	1220	620	400	6	92	265	819	250	255	415,8	2830

(1) For higher speed, please consult.

(2) Max. bore for keyways to DIN 6885/1

(3) S & S1= Space necessary to mount grids.

(4) $GD^2 = 4J$. // (4) and (5) values with no bore.